



RT 100US

Rough terrain crane
Datasheet
metric



RT 100US

WORKS FOR YOU.™

DIMENSIONS

RT 100US

DIMENSIONES

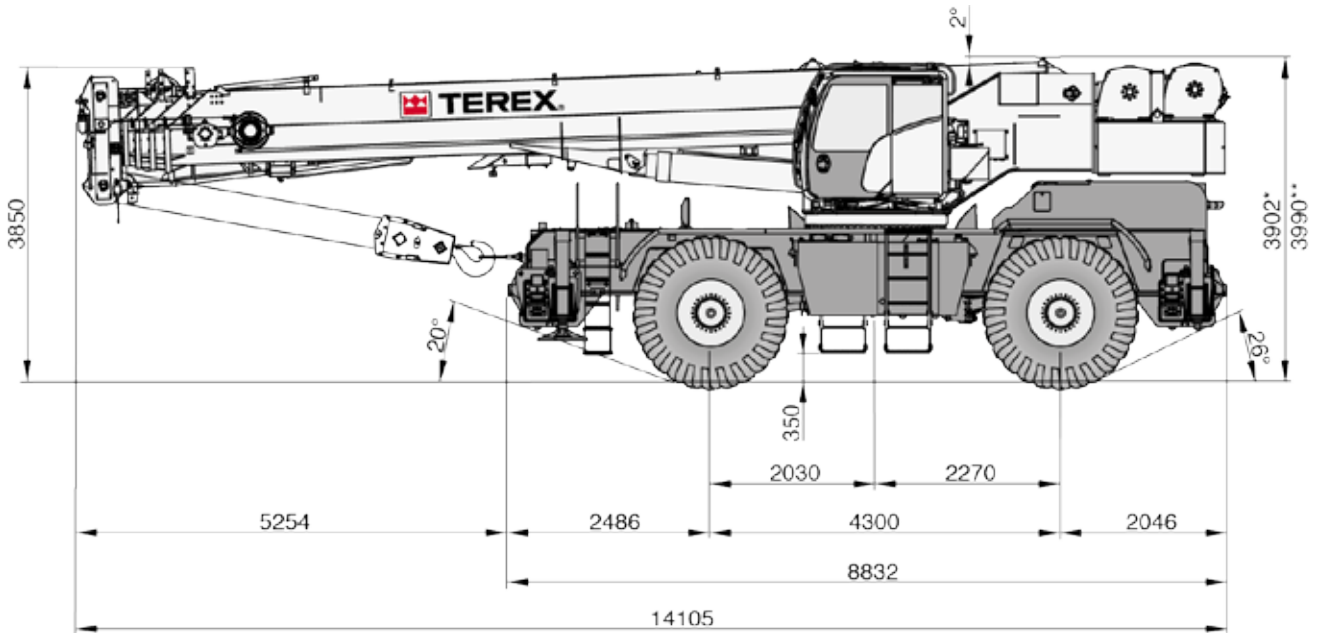

* 26.5R25
** 29.5-25

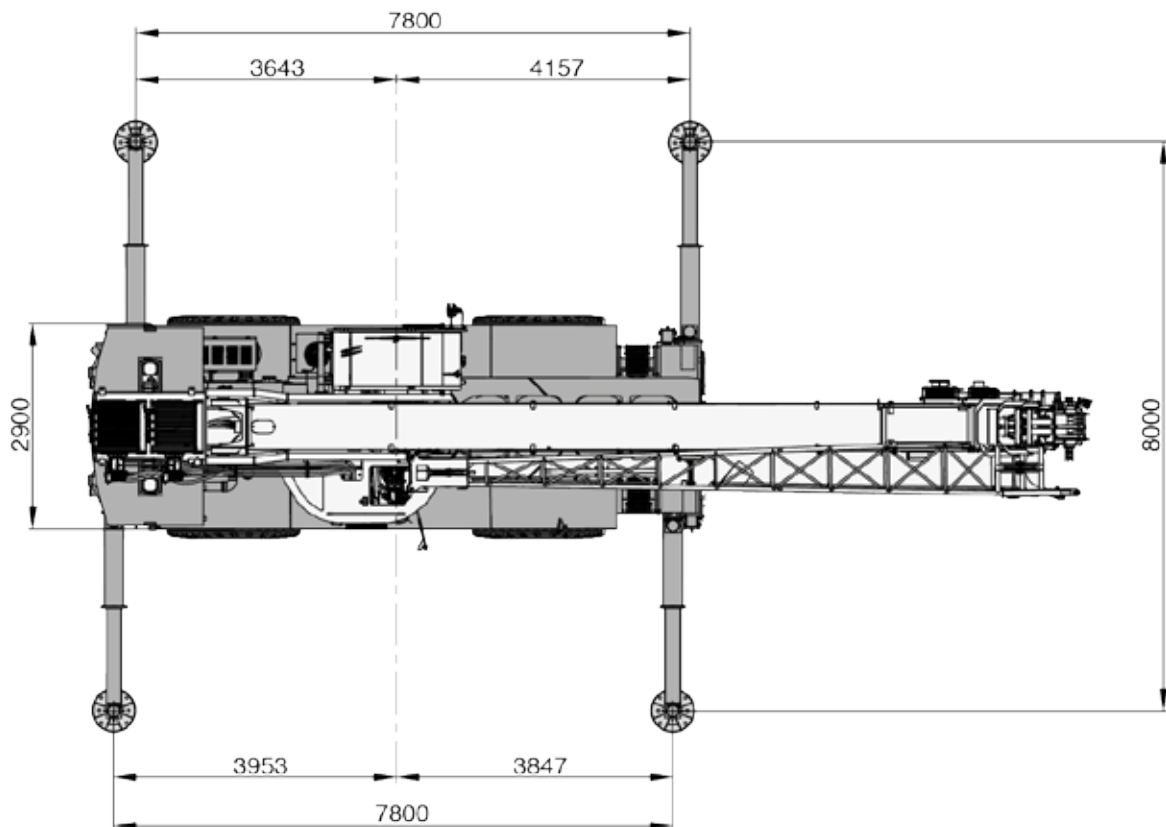

RANGE DIAGRAM - MAIN BOOM

RT 100US

DIAGRAMA DE CARGA · GRÁFICO DE ALCANCE

Outriggers Fully Extended (100%) · Estabilizadores totalmente extendidos (100%) · Extensão máxima dos estabilizadores (100%) · Stabilisateurs entièrement déployés (100%) - 3 Modes

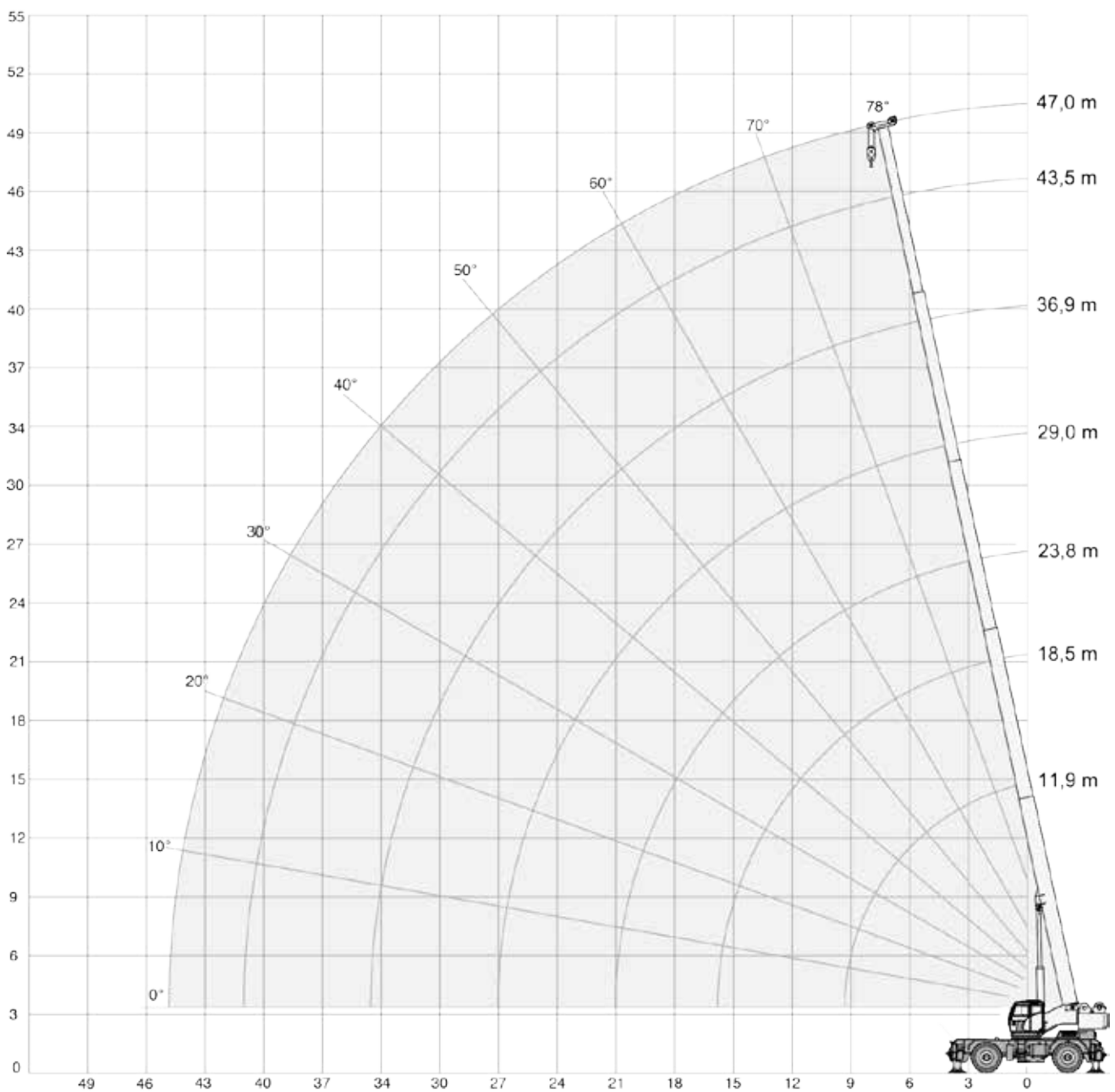
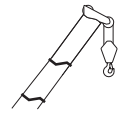
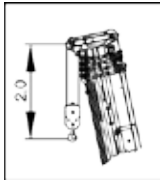

LOAD CHART – MAIN BOOM

RT 100US

TABLA DE CARGA · TABELA DE CARGA

Outriggers Fully Extended (100 %) · Estabilizadores totalmente extendidos (100 %) · Extensão máxima dos estabilizadores (100 %) · Stabilisateurs entièrement déployés (100 %) – 3 Modes



10 t



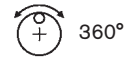

7,8 x 8,0 m
(100 %)



360°

Standard ASME
B30.5

								
	11,9 m	18,5 – 18,9 m	23,8 – 25,1 m	29,9 – 31,2 m	36,5 – 36,9 m	43,1 – 43,5 m	47,0 m	
		t	t	t	t	t	t	m
	90,0*							
2,5	87,0							2,5
3	80,0	46,4						3
3,5	73,2	42,6						3,5
4	67,4	39,1						4
4,5	62,4	36,3	35,7					4,5
5	56,9	36,1	35,7					5
6	45,7	36,1	35,7					6
7	38,0	36,1	33,8	20,7				7
8	32,3	33,1	31,3	18,4				8
9	28,0	28,7	28,9	16,6	15,3			9
10		25,3	25,5	15,1	15,0			10
12		18,7	19,2	12,5	13,3	10,8	8,9	12
14		14,2	14,6	10,6	11,5	9,4	8,8	14
16		11,2	11,5	9,0	10,0	8,7	7,4	16
18			9,3	7,6	8,7	7,7	6,3	18
20			7,7	6,0	7,0	6,8	5,4	20
22			6,4	4,7	5,6	6,0	4,6	22
24				3,6	4,5	4,9	4,0	24
26				2,8	3,6	4,0	3,4	26
28				2,1	2,9	3,3	2,9	28
30					2,3	2,6	2,2	30
32					1,7	2,1	1,7	32
34					1,3	1,6	1,2	34
36						1,2	0,8	36
38						0,8		38

* special equipment needed · equipamiento especial necesario · equipamento especial necessário · équipement spécial requis

Notes to lifting capacity · Condiciones de utilización · Notas sobre capacidade de içamento · Conditions d'utilisation:

see page 22 · ver página 22 · ver página 22 · voir page 22

RANGE DIAGRAM - JIB

RT 100US

DIAGRAMA DE CARGA · GRÁFICO DE ALCANCE

**17 m offset · 17 m Angulamiento · Projeção de 17 m · Déport 17 m
- 3 Modes**

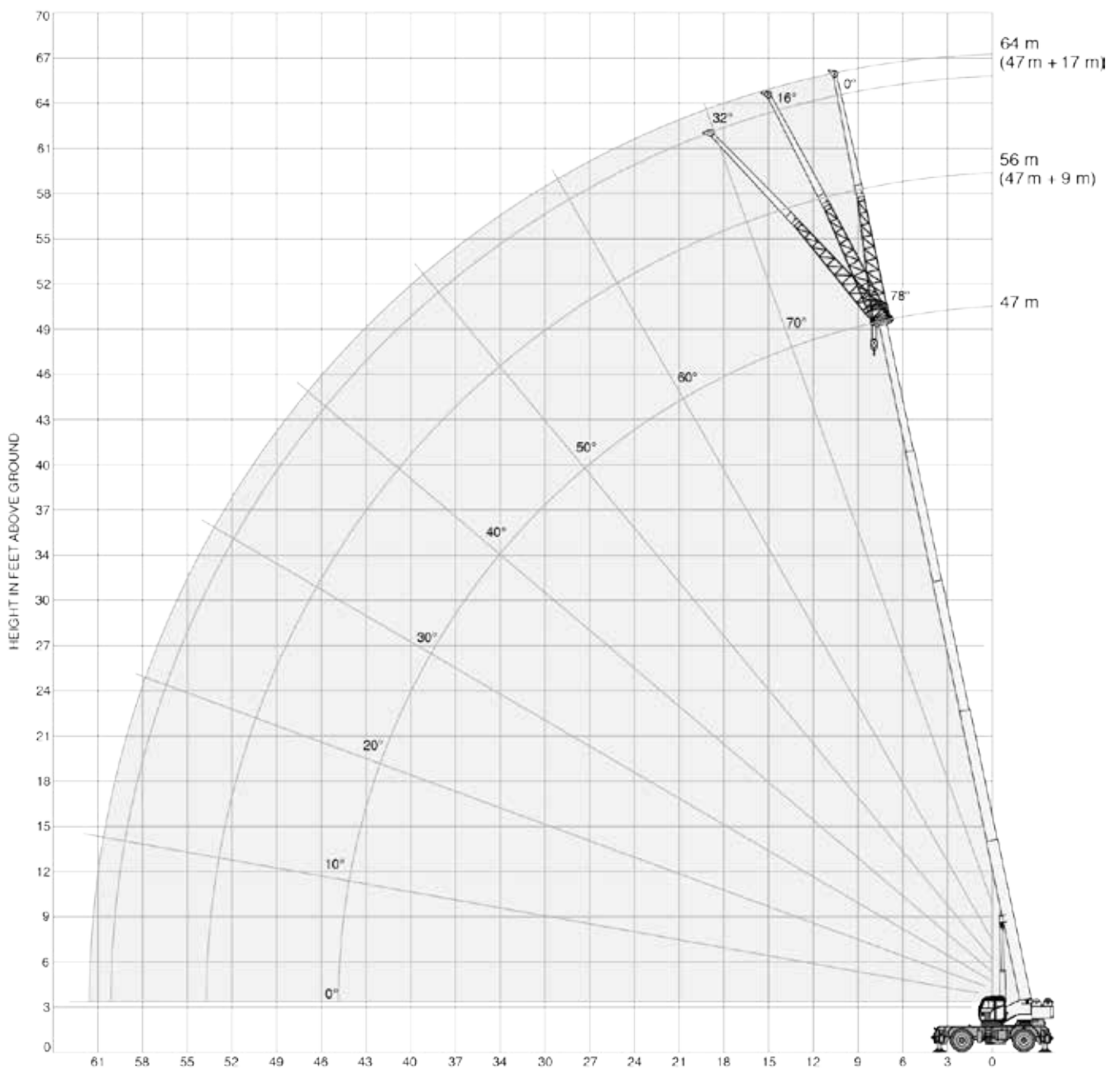
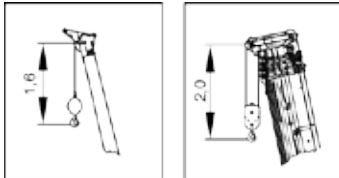
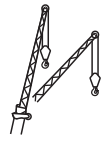

LOAD CHART - JIB

RT 100US

TABLA DE CARGA · TABELA DE CARGA





Outriggers Fully Extended (100%) · Estabilizadores totalmente extendidos (100%) · Extensão máxima dos estabilizadores (100%) · Stabilisateurs entièrement déployés (100%) - 3 Modes

 10 t

 7,8 x 8,0 m
(100 %)

 360°

Standard ASME
B30.5

 47 m							
	 9 m			 17 m			
	0°	16°	32°	0°	16°	32°	
m	t	t	t	t	t	t	m
16	5,0						16
18	5,0	5,0					18
20	5,0	4,7	4,3	3,1			20
22	4,6	4,3	4,0	3,1	2,5		22
24	4,0	4,0	3,7	3,0	2,5		24
26	3,4	3,6	3,5	2,9	2,4	2,1	26
28	2,8	3,2	3,2	2,8	2,4	2,0	28
30	2,2	2,5	2,9	2,3	2,3	2,0	30
32	1,6	2,0	2,2	1,8	2,2	2,0	32
34	1,1	1,5	1,7	1,4	2,0	1,9	34
36	0,7	1,0	1,2	1,0	1,6	1,9	36
38			0,8	0,7	1,2	1,6	38
40					0,8	1,2	40
42						0,8	42

Notes to lifting capacity · Condiciones de utilización · Notas sobre capacidade de içamento · Conditions d'utilisation:

see page 22 · ver página 22 · ver página 22 · voir page 22